

▶ CONTENTS

The images shown below are for reference only. Actual contents may vary.

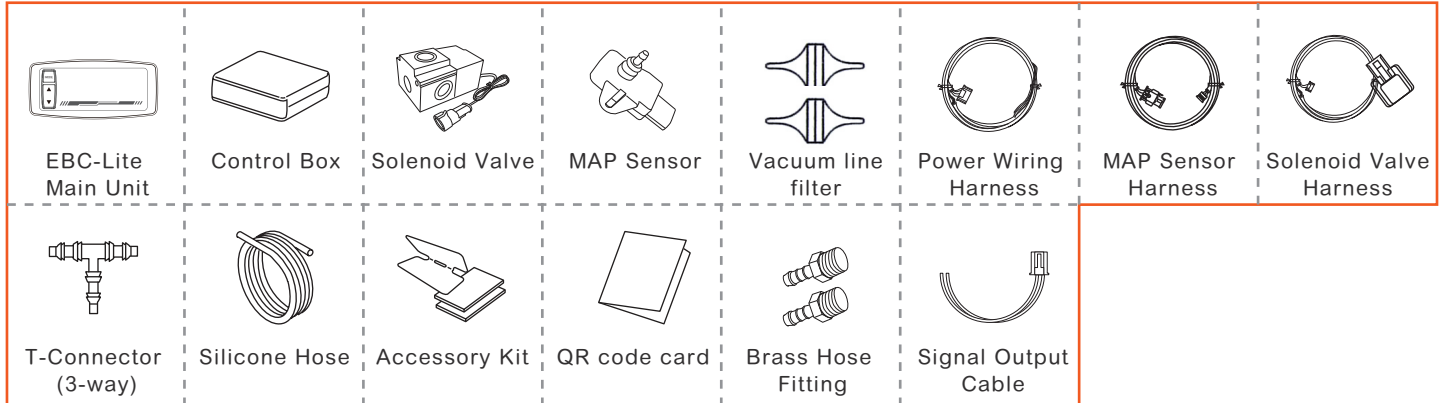

- If the product is transferred to another user, please ensure this instruction manual is included.

▶ FEATURES

- Simple operation design for quick and intuitive boost adjustment, improving safety during tuning.
- Equipped with a digital display to show current boost pressure in real time.
- Utilizes a high-precision PWM boost control IC for accurate and stable pressure regulation.
- Compatible with mechanical Wastegate or Actuator-based turbo systems.
- Supports pressure units Bar and PSI ($\times 100$ kPa), selectable according to user preference.
- Provides A/B preset modes and N (stock) mode, allowing quick switching based on driving conditions.
- A/B modes support Peak (maximum boost) memory, enabling review of the highest boost reached.
- Supports external 12V output, allowing configurable trigger values for auxiliary devices or electronic control.
- Adjustable overboost protection, with warning indication and automatic boost reduction to protect the engine.

▶ IMPORTANT

- This product is suitable only for engines equipped with mechanical 「 Wastegate / actuator 」 type turbo systems.
- Not compatible with engines using 「 Electronic Wastegate (EWG) 」 or systems where boost is directly controlled by the ECU.

- Please read this instruction manual carefully before installation to ensure optimal performance of the EBC-Lite.
- EBC-Lite is an external boost control device. Its primary function is to stabilize and adjust boost pressure. It is not an ECU tuning device and cannot modify fuel supply, ignition timing, or other engine management parameters.
- The adjustable boost range depends on multiple factors, including the vehicle configuration, wastegate spring pressure, turbocharger efficiency, and overall engine condition.
- EBC-Lite can only increase boost pressure above the mechanical spring pressure and cannot reduce boost below the factory base boost level.
(Example: If the factory wastegate spring pressure is 1.0 bar, EBC-Lite cannot reduce boost pressure below 1.0 bar.)
- Before making adjustments, always verify that the fuel system is operating properly.
If the vehicle hardware configuration is insufficient, improper boost adjustment may result in insufficient fuel delivery, potentially causing engine knocking or lean combustion.
- If excessive boost pressure is required, it is recommended to first complete all necessary hardware upgrades to ensure system safety and stability.

- Proper routing of vacuum hoses is critical to boost control performance. Use 4 mm vacuum hoses and ensure all connections between the turbocharger, solenoid valve, and wastegate actuator are secure and free of leaks. Aging, cracking, or blockage of vacuum hoses may cause unstable boost control or delayed response.
- EBC-Lite is a precision electronic device.

Installation and setup are strongly recommended to be performed by qualified or experienced technicians to ensure system safety and correct operation.

▶ OPERATION INSTRUCTION

MODE Button
Short Press: Switch operating mode (N / A / B)
Long Press: Enter Setting Mode (SET) for the current mode

UP / DOWN Buttons
Short Press: UP : Display Peak Value (PEAK)
-Short press UP, or automatically return to the main screen after 5 seconds
-Short press DOWN to clear the peak value

Long Press: (2 sec)
UP : Enter Warning Value Setting
-Automatically returns to the main screen after 5 seconds
DOWN: Switch pressure unit (BAR / PSI)
UP+DOWN: Perform Pressure Zero Calibration (Refer to the detailed calibration instructions)

SETTING
Lights up when the unit is in setting mode

PEAK
Displays the maximum boost pressure reached

Percentage Display (ICON)
Indicates percentage-based parameters during setup

MODE Indicator (N / A / B)
Shows the currently selected operating mode

Boost Value Bar Graph
Visual representation of boost pressure (From boost onset to high boost range)

Basic Wiring Diagram

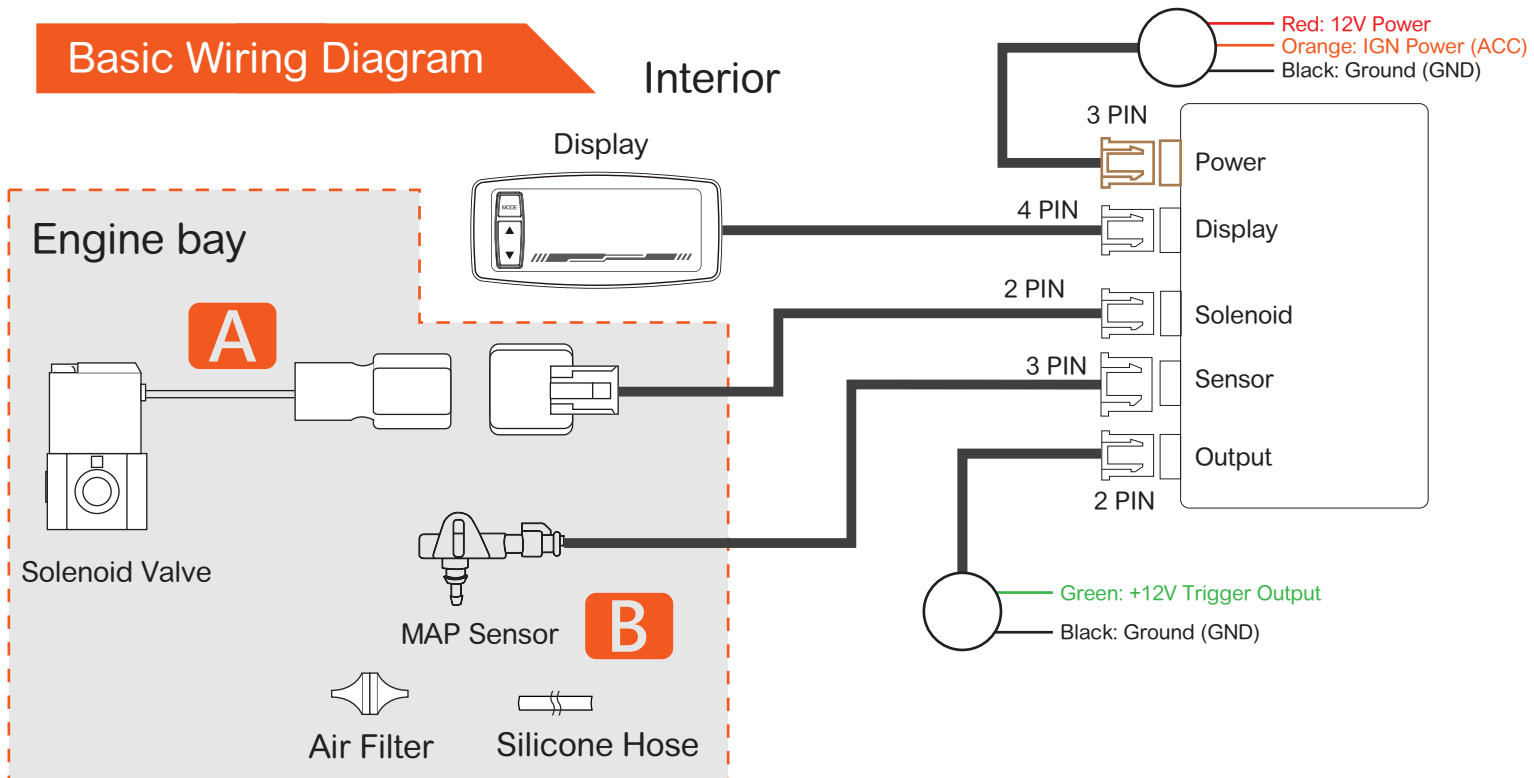

A B Follow the system diagram above to complete the installation.

► INSTALLATION INSTRUCTION

Recommended Installation & Setup Procedure :

1. After starting the vehicle, confirm that the engine is operating normally, with no abnormal noise or warning indicators.
2. Perform initial testing under low load conditions in a safe area or on a closed road.
3. Begin boost adjustments by setting GAIN and DUTY to their minimum values, then increase gradually.
4. Make one adjustment at a time, and apply changes in small increments to ensure stable and safe operation.

Actuator

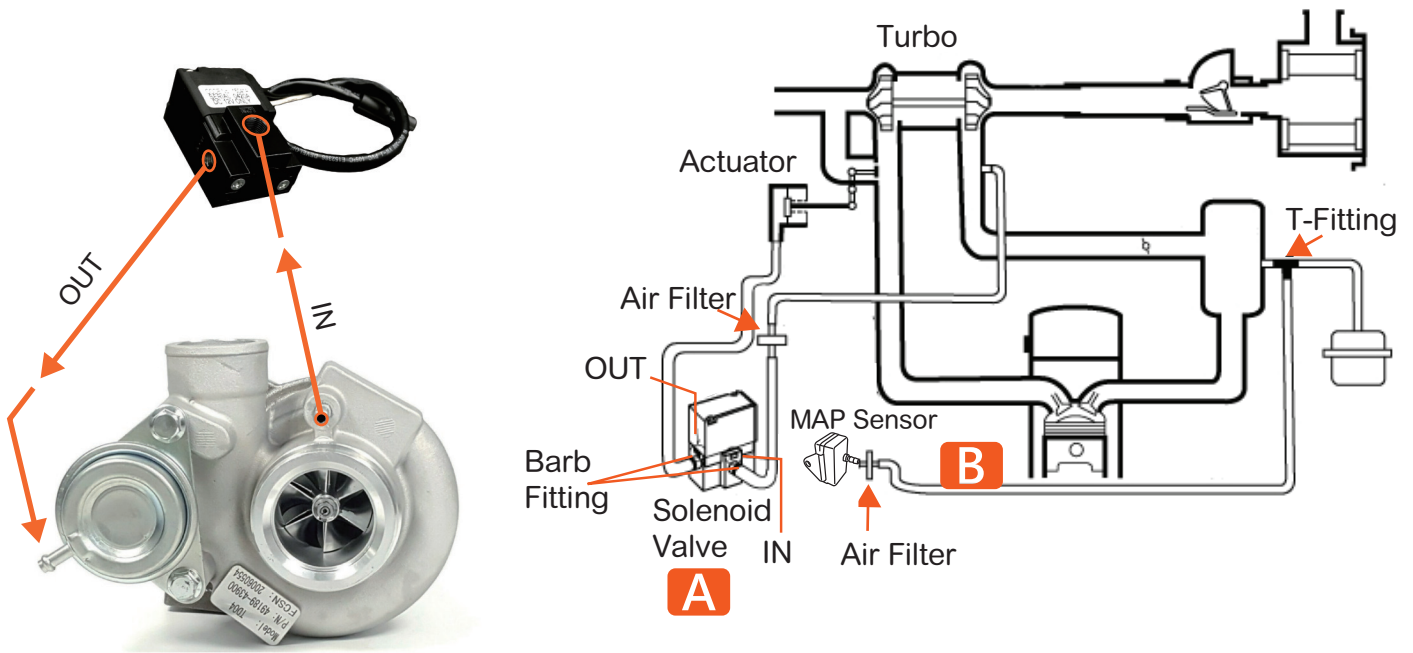

Wastegate

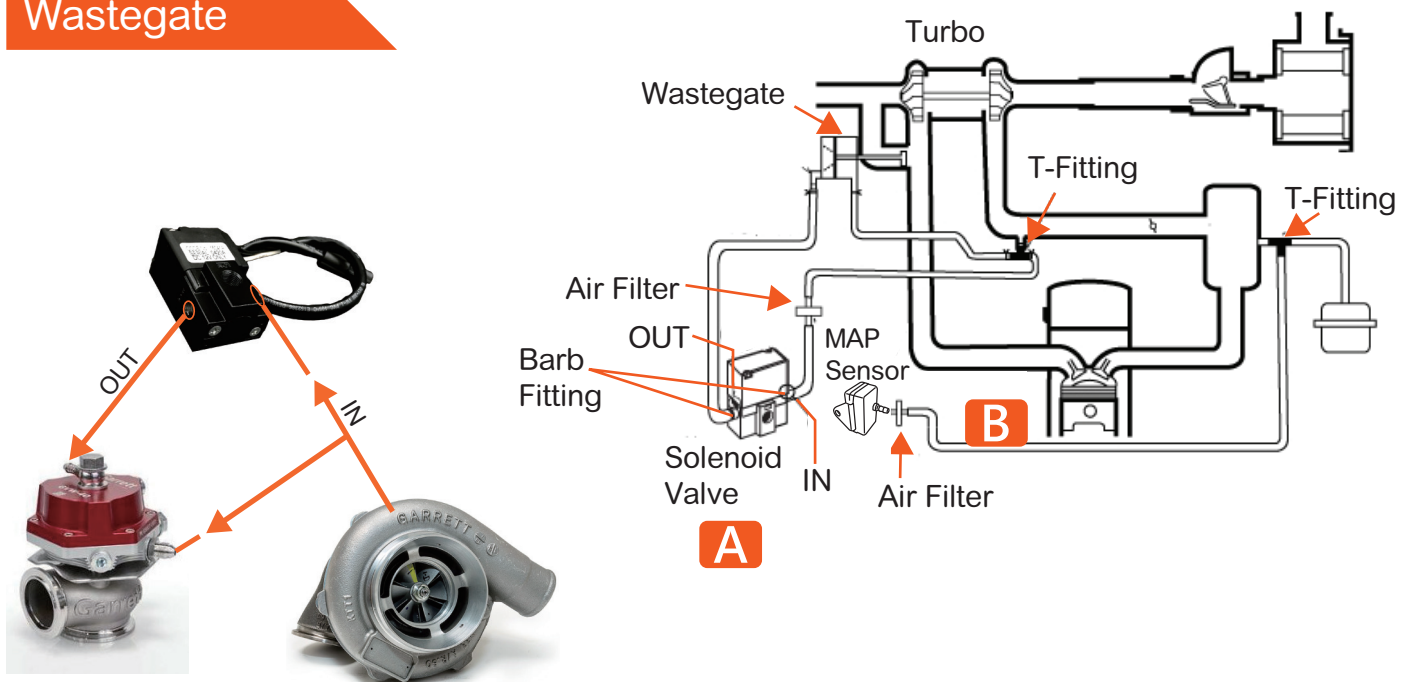

TUNING INTERFACE



Custom boost parameters for Mode A and Mode B

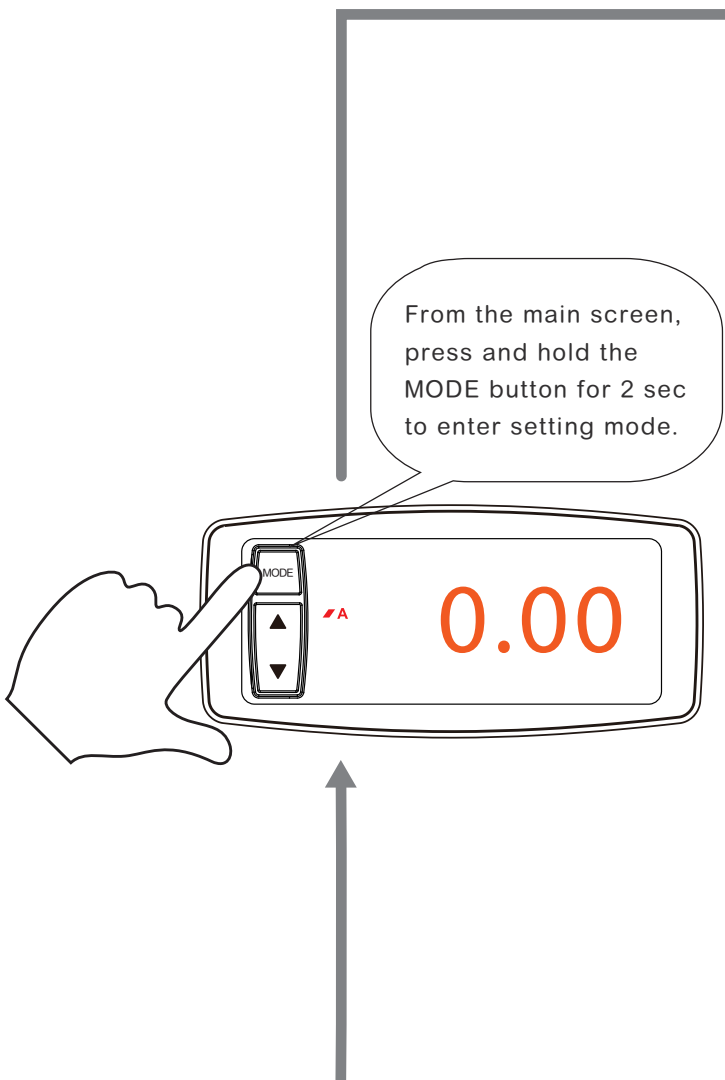

1

START (s)

SET indicator will flash

The active value flashes during adjustment.

Increase

Decrease

MODE SET

▲ A S 0.3 ▼

Sets the boost control activation point.

If no operation is performed for 5 sec, or by short-pressing MODE, the system moves to the next parameter.

2

DUTY (d)

Increase

Decrease

MODE SET

▲ A d 45 ▼

Adjusts the solenoid duty cycle to control the overall boost pressure level.

3

GAIN (g)

Increase

Decrease

MODE SET

▲ A g 9 17 ▼

Adjusts how smoothly the duty cycle rises as boost builds.

4

HIGHT BOOST LIMIT (H)

Increase

Decrease

MODE SET

▲ A H 1.6 ▼

Exceeding this value forces boost control to disengage and releases boost pressure.

5

Output Trigger (O)

Increase

Decrease

MODE SET

▲ A O 0.8 ▼

Outputs a 12V trigger signal to activate external devices when the preset boost value is reached.



Boost parameters in A / B modes must be adjusted by the user based on the specific vehicle configuration. Factory default values may not be suitable for all applications.

EBC-lite Boost Control Curve

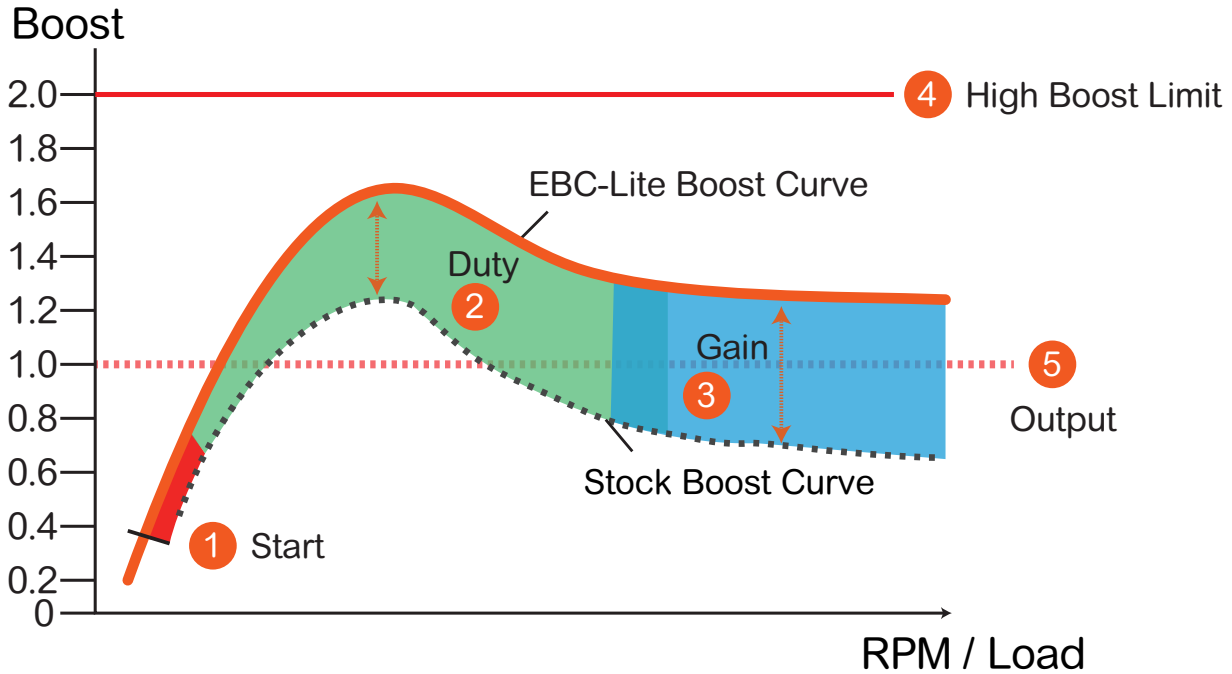

- 1** **Start (S)** Defines the boost control activation point. Boost control starts once this value is reached. (Range: from 0.10 bar)

 - 2** **Duty (d)** Controls the solenoid output level, directly affecting overall boost. Higher values result in higher boost. (Range: 0 – 100%)

 - 3** **Gain (g)** Adjusts how the duty cycle increases as boost builds. Used to fine-tune boost buildup behavior. (Range: 0 – 100%)

 - 4** **High Boost Limit (H)** Safety limit. When exceeded, boost control is disabled and pressure is released. (Range: from Start value to 3.00 bar)

 - 5** **Output (O)** Sets a boost pressure threshold. When the preset value is reached, a +12V / 1A trigger signal is output to activate external devices.
- Trigger settings are stored separately for Mode A and Mode B. The output is automatically disabled when boost falls below the preset value. (Range: 0.10 – 3.00 bar)

▶ SETTINGS

1. Mode Switching

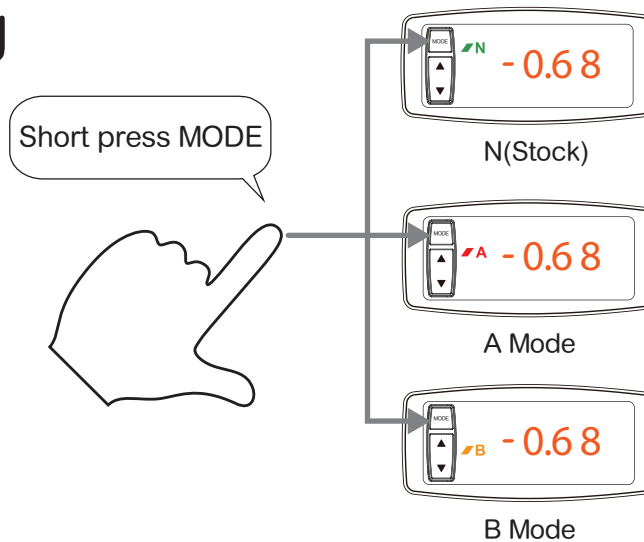

2. Unit Switching

Default unit: BAR

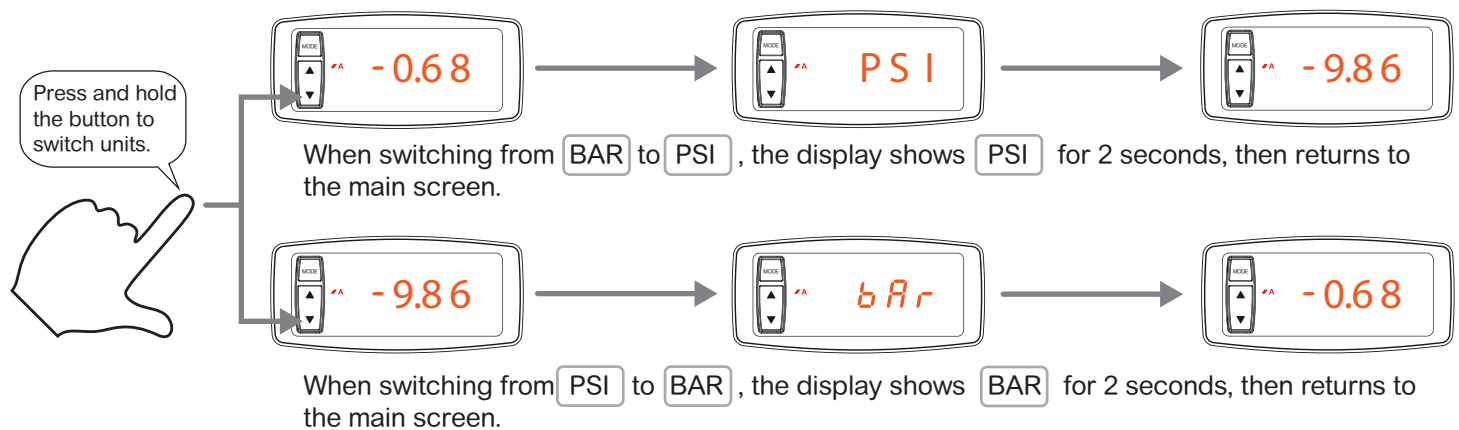

3. Warning Setting

Default unit: BAR

Default value: 1.5 BAR

When boost exceeds the value, the display will flash.

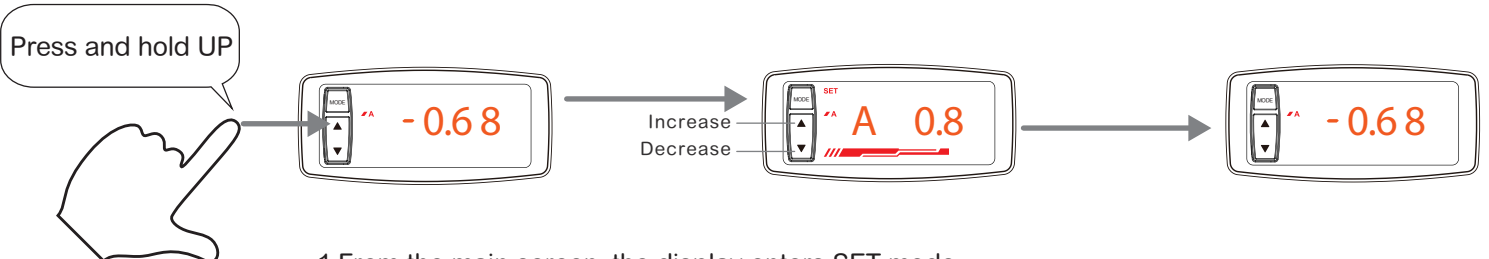

1. From the main screen, the display enters SET mode.
2. Use UP / DOWN to increase or decrease the value (0.1 increments).
3. The value flashes while being adjusted.
4. After 5 seconds of inactivity, the unit returns to the main screen.

4. PEAK Value

PEAK values are stored separately for Mode N / A / B.

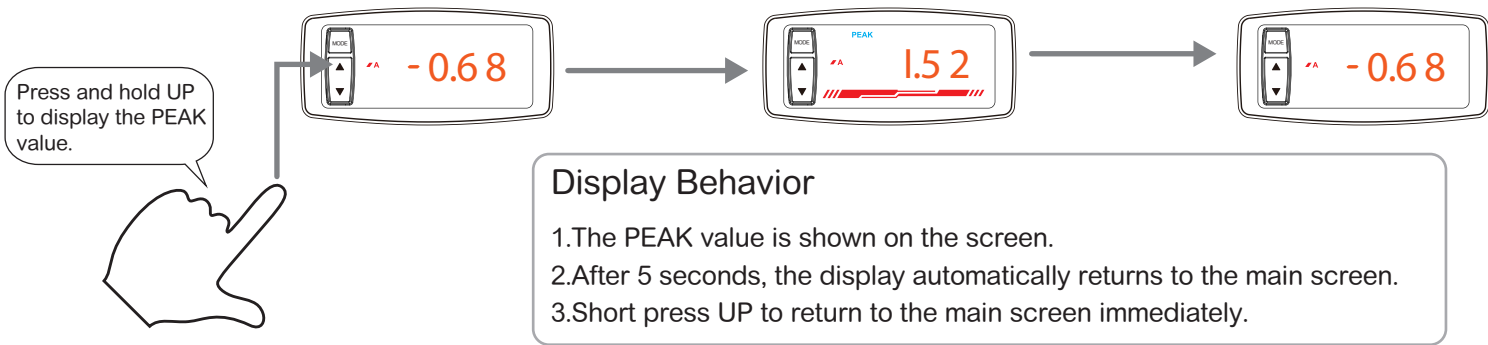

Display Behavior

- 1.The PEAK value is shown on the screen.
- 2.After 5 seconds, the display automatically returns to the main screen.
- 3.Short press UP to return to the main screen immediately.

Clear PEAK Value

- 1.Short press DOWN while the PEAK value is displayed to clear the stored PEAK value.
- 2.After clearing, the display returns to the main screen.

5. Zero Point Calibration

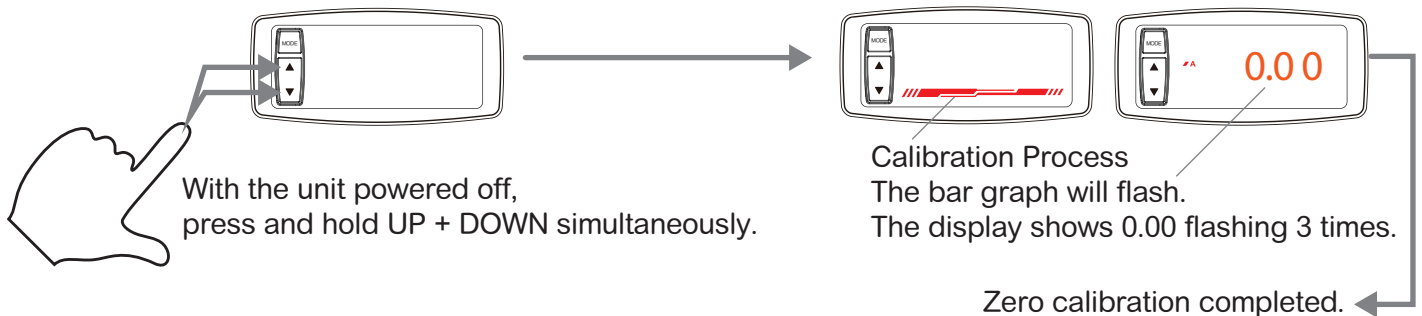

6. Device Reset

- 1.From the main screen, press and hold MODE + UP + DOWN simultaneously.
- 2.After 3 seconds, the display will turn off and the unit will reboot.



Troubleshooting

When you think the machine is faulty, please confirm the following items before sending it for repair:

Abnormal Condition	Possible Cause	Analysis & Action
No display after power ON	Improper power wiring	Verify power wiring. Red/Orange: +12V Black: GND
No reading displayed	Sensor signal lost	Check pressure sensor and harness connection.
No boost reading before engine start	Sensor zero drift	Perform baseline calibration before engine start.
Unable to reach target boost	Exceeds mechanical limit	Adjust Gain and Duty (0-100%). Boost depends on turbo setup.
	Turbo or engine issue	Inspect ECU and related sensors.
	Hose leak or misrouting	Check all intake and boost hoses for leaks.
	Controller error	Perform RESET.
	Incorrect wastegate spring	If base spring pressure exceeds target, boost cannot be reduced below spring rating.
Boost unstable or sudden overboost	Wiring or hardware issue	Stop operation immediately and inspect system.
	Solenoid malfunction	Check solenoid and vacuum hoses.
	Pressure valve malfunction	Verify valve operation.

Return for service with complete unit and accessories.



Address: NO.163 Fan-Hwa Road, Chin-Hsin Village, Hsiu-Shui, Chang Hwa, TAIWAN
Tel: +886-4-7681140 Fax: +886-4-7698587 E-mail: info@autojaw.com

Copyright 1999-2026 AUTO JAW CO,LTD ALL Rights Reserved.

